



SUBARU

SUBARU

PART NUMBER: E201SAJ500

**INSTALLATION
INSTRUCTIONS**

DESCRIPTION: OUTBACK WHEEL ARCH MOLDING

KIT CONTENTS:

A.

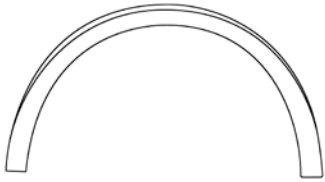

Left Front Molding x 1

B.

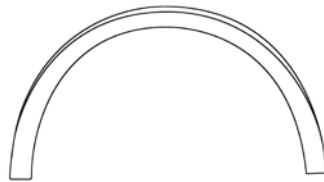

Right Front Molding x 1

C.

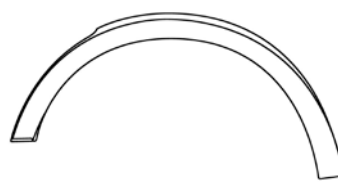

Left Rear Molding x 1

D.

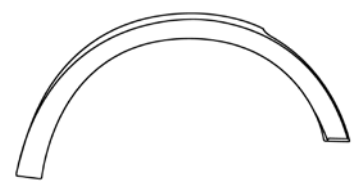

Right Rear Molding x 1

E.

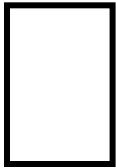

Plastic Tab
x 18

F.



Two Piece Clamp
Clip x 12

G.



#10 5/8" Truss
Head Screw x 18

H.

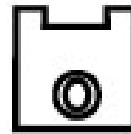

Metal "U" Clip x 6

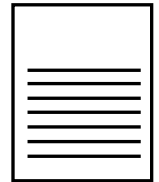

Installation
Instructions x 1

TOOLS REQUIRED:

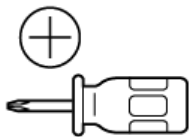

#2 Stubby Phillips or
Ratcheting Screwdriver



Grease Pencil



Drill with 1/4" Drill
Bit and Drill Stop



Needle Nose
Pliers

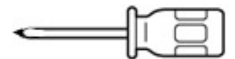

Awl

PART NUMBER:
E201SAJ500









ISSUE:
00

DATE:
5-9-13

SUBARU OF AMERICA

PAGE
1/7

MEANING OF CHARACTERS:

-  : Remove
-  : Install
-  : Disconnect
-  : Connect
-  : Location of Clip or Screw
- T** : Tightening Torque
-  : Loosen
-  : Discard
-  : Reuse

Surface Preparation

1

Make sure that all installation surfaces (shown below) are clean, free of dirt, grease, and debris. If necessary, use a clean, lint-free cloth and alcohol based cleaner. Inspect vehicle for damage before installation of body kit.

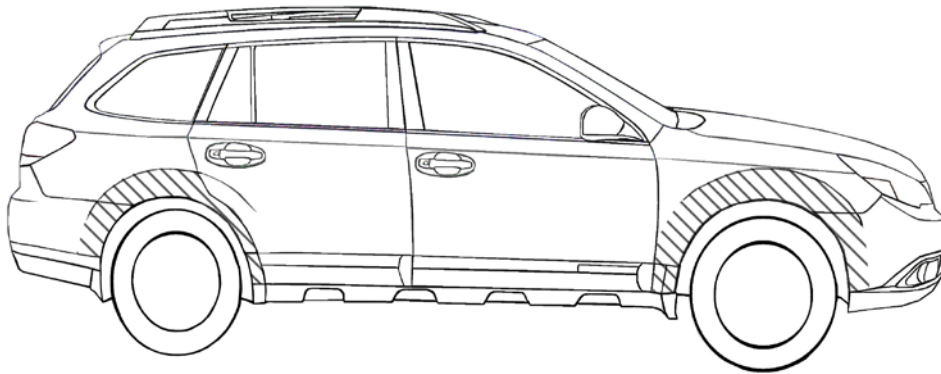

Front Molding Installation

2

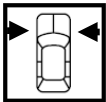

Remove one factory fastener.

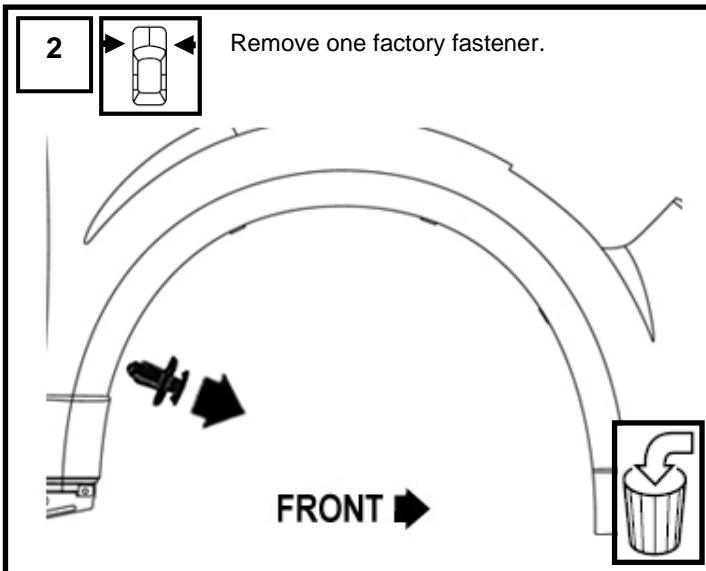

3

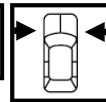

Center and fold a Plastic Tab over rearmost factory hole, behind splash shield onto sheet metal.

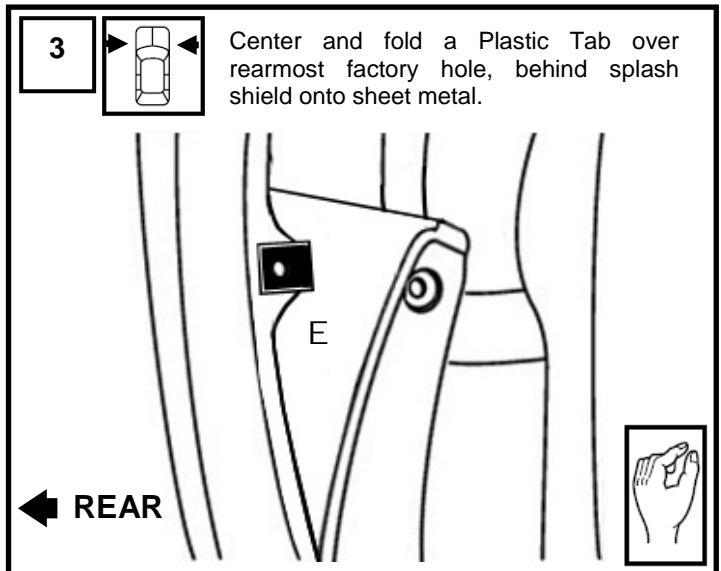

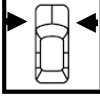
4  Install supplied Metal "U" Clip over rearmost factory hole, behind splash shield onto sheet metal, over Plastic Tab installed in step 3, with flat side facing wheel well. Use awl to poke hole through Plastic Tab.

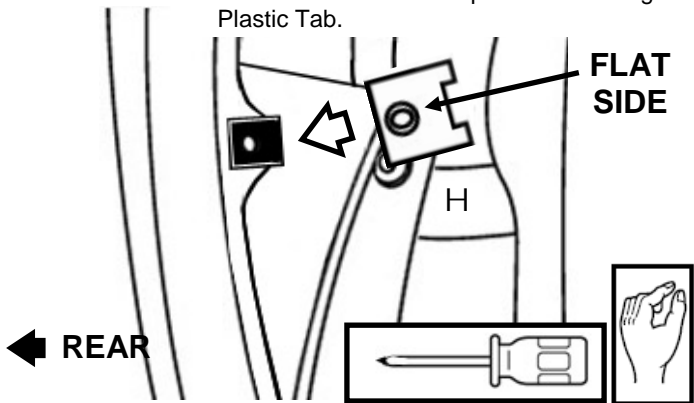

FLAT SIDE

REAR ←

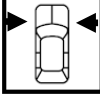
5  Position molding on fender, and install supplied #10 Truss Head Screw through molding and into Metal "U" Clip. Do not tighten.

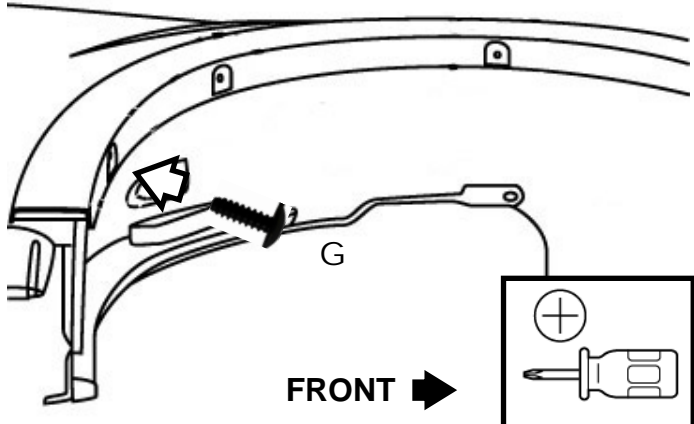

FRONT →

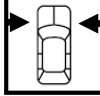
6  Pushing up on molding, use a grease pencil to mark 3 two-piece Clamp Clip locations on fender.

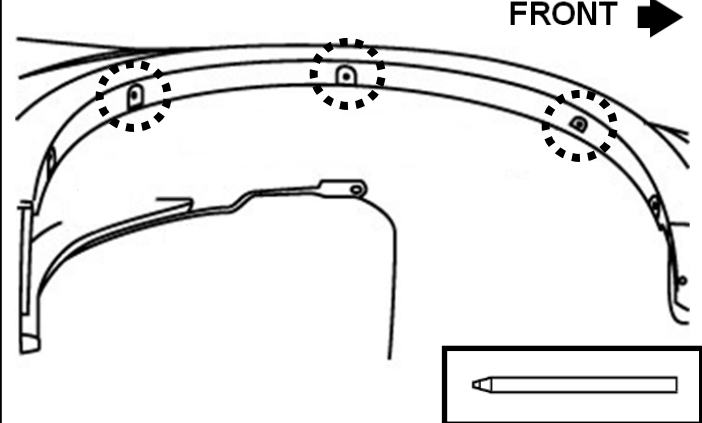

FRONT →

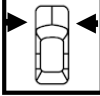
7  Remove screw installed in Step 5 and remove molding from fender.

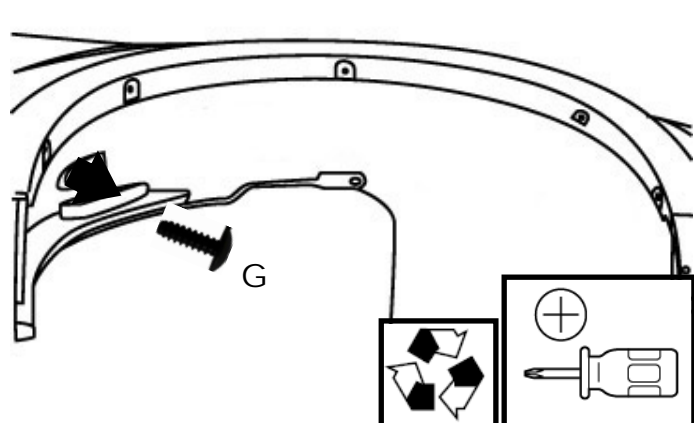

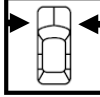
8  Fold supplied Plastic Tab in half. Peel liner and center Tab over each mark made in Step 6, folding over edge of fender lip (3 places). Place a second tab over circled area so there are two tabs at this location.

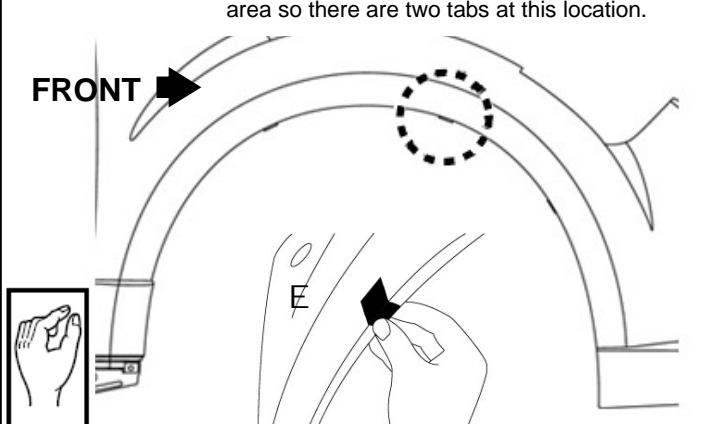

FRONT →

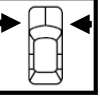
9  Slide supplied two piece Clamp Clip onto Plastic Tab (3 places).

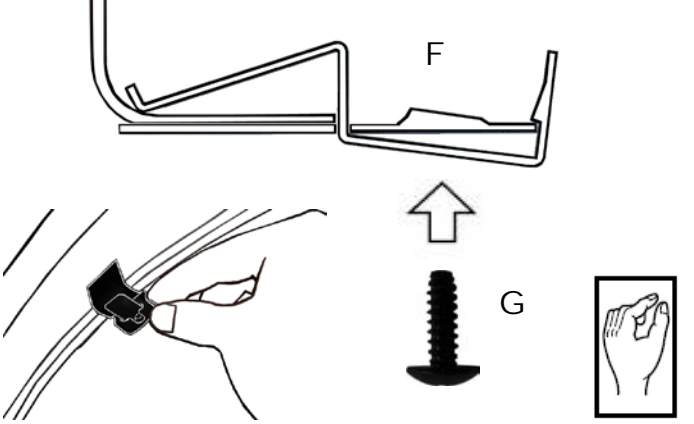

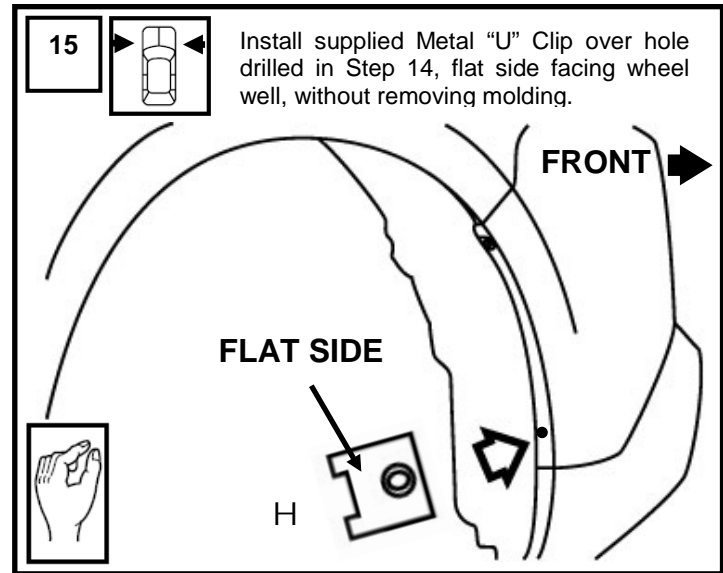
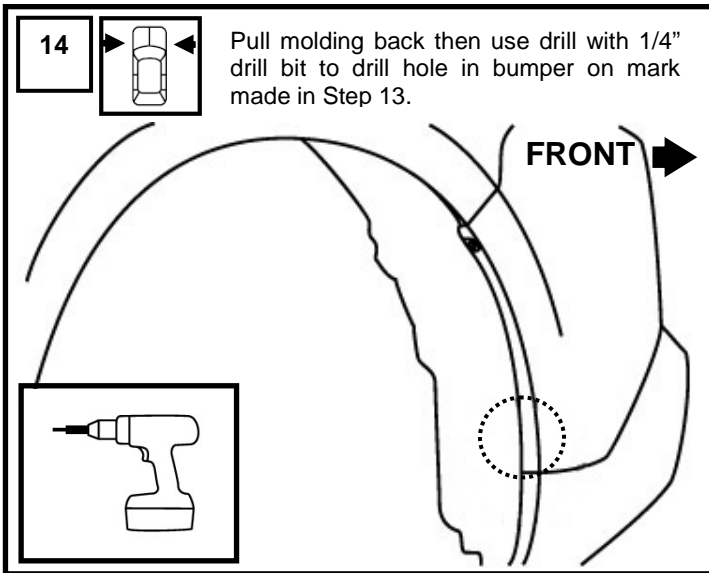
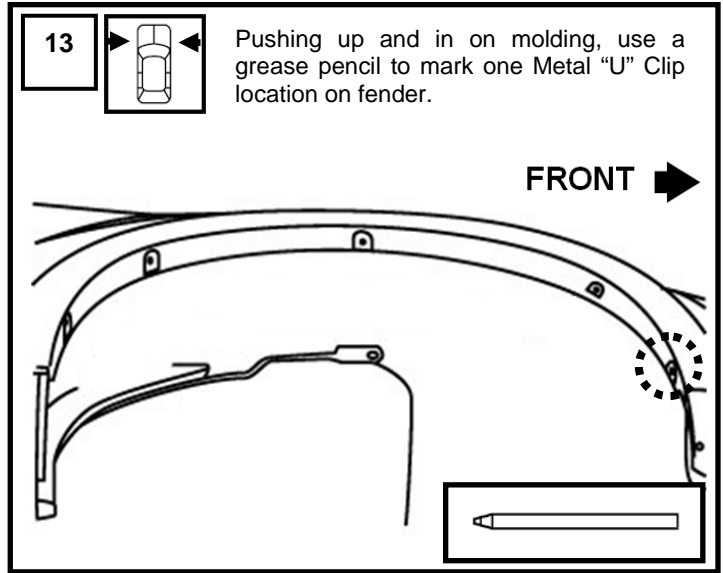
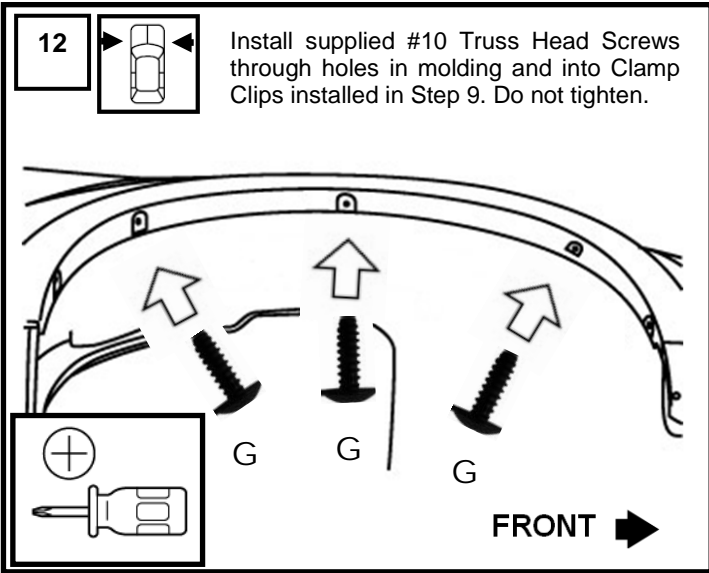
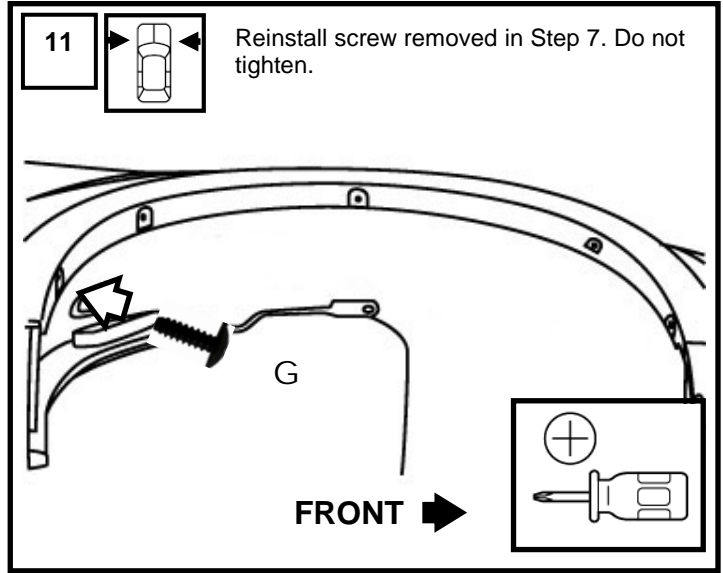
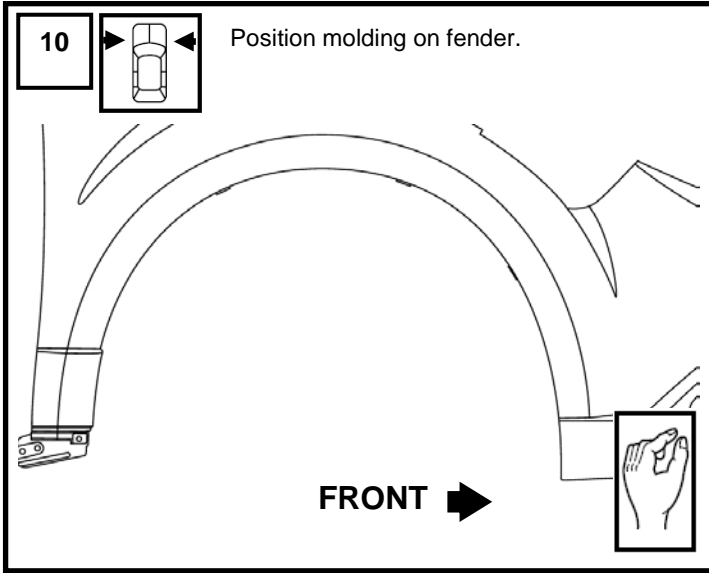

16

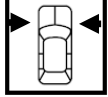

Install supplied #10 Truss Head Screw through molding and into Metal "U" Clip installed in Step 15. Do not tighten.

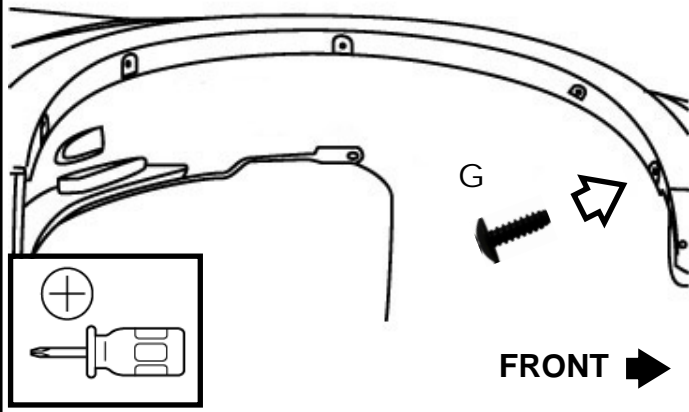

17

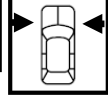

Ensure that molding is properly positioned on fender. Apply pressure at each fastening point, and tighten all screws. Repeat Step 1 – Step 17 for other side.

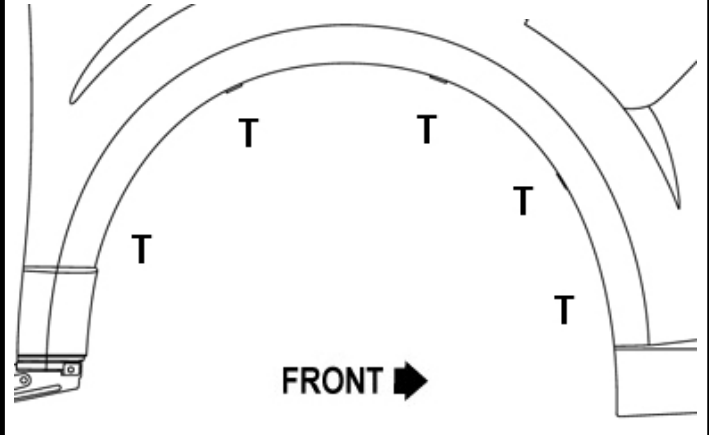

Rear Molding Installation

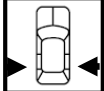
18  Install supplied Metal "U" Clip on tab beneath rearmost factory hole, flat side facing wheel well.

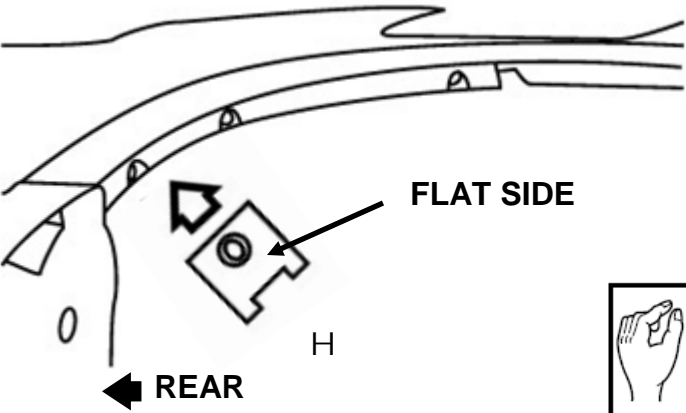

FLAT SIDE

H

REAR

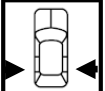
19  Position molding on fender, install supplied #10 Truss Head Screw through molding and into Metal "U" Clip installed in Step 18. Do not tighten.

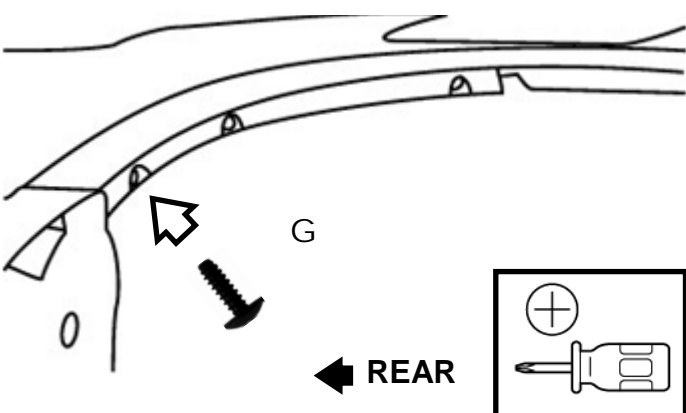

G

REAR

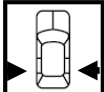
20  Pushing up on molding, use a grease pencil to mark 3 two-piece Clamp Clip locations on fender.

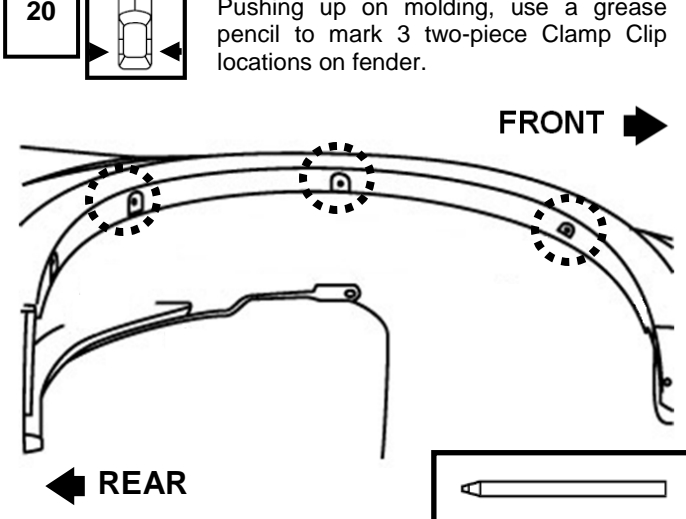

FRONT

REAR

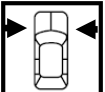
21  Remove screw installed in Step 19 and remove molding from fender.

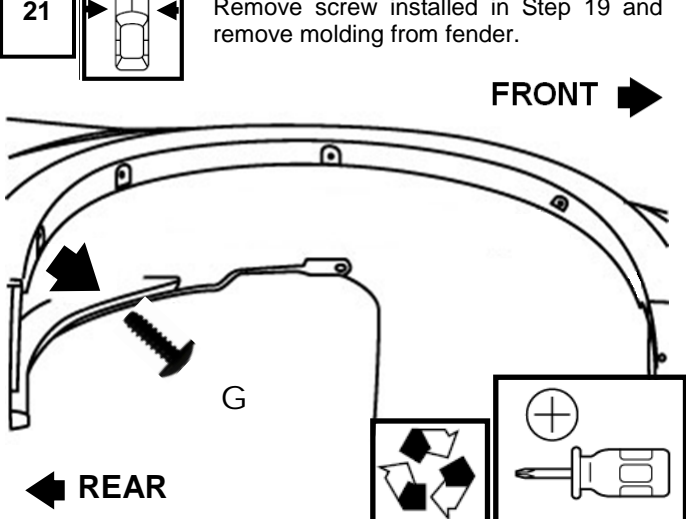

G

FRONT

REAR

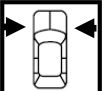
22  Fold supplied Plastic Tab in half. Peel liner and center Tab over each mark made in Step 20, folding over edge of fender lip (3 places). Place a second tab over area so there are two tabs at this location.

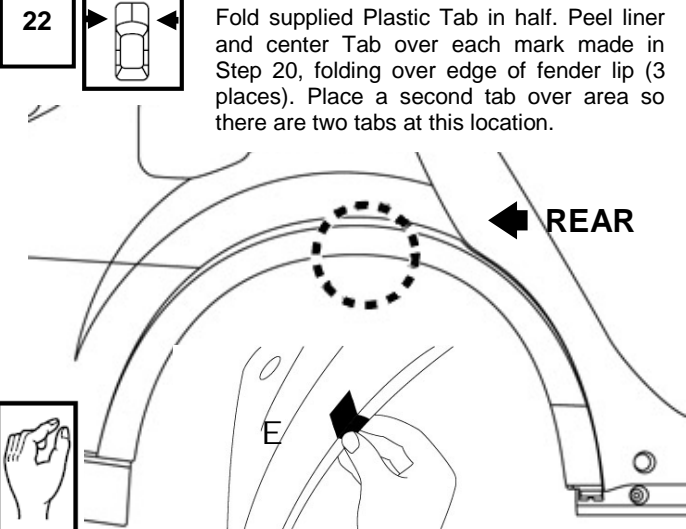

E

REAR

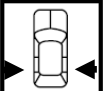
23  Slide supplied two piece Clamp Clip onto Plastic Tab (3 places).

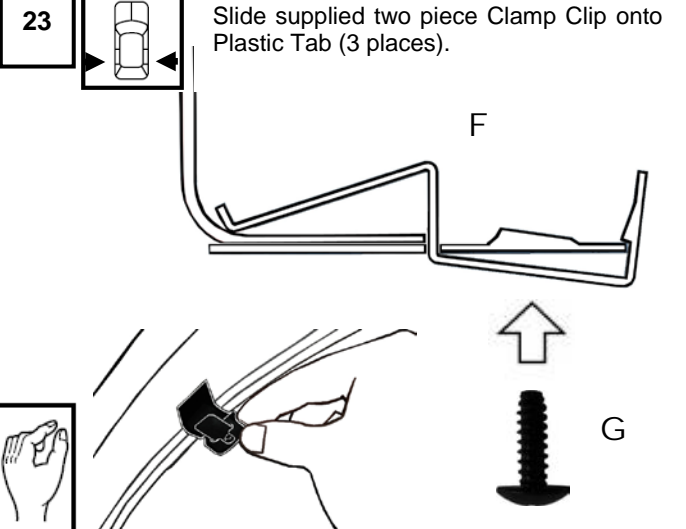

F

G

